

Link Budget Analysis: Getting Started

www.AtlantaRF.com



Atlanta RF

Services, Software & Designs

Presentation Content

Link Budget Analysis: Getting Started

1. Link Budget: What's That?
2. Types of Communication Links.
3. Benefits of a Link Budget.
4. How Many Link Budget Analysis?
5. Power Transfer into Free Space.
6. Link Power Budget Equation.
7. Propagation Path Loss Models.
8. Noise Power & Spectral Density.
9. Antenna Noise.
10. Signal-to-Noise Ratio.
11. Digital Transmission.
12. Link Performance Criteria.
13. Energy per bit & Eb/No.
14. Sources of Link Degradation.
15. Summary: Link Budget Equations.

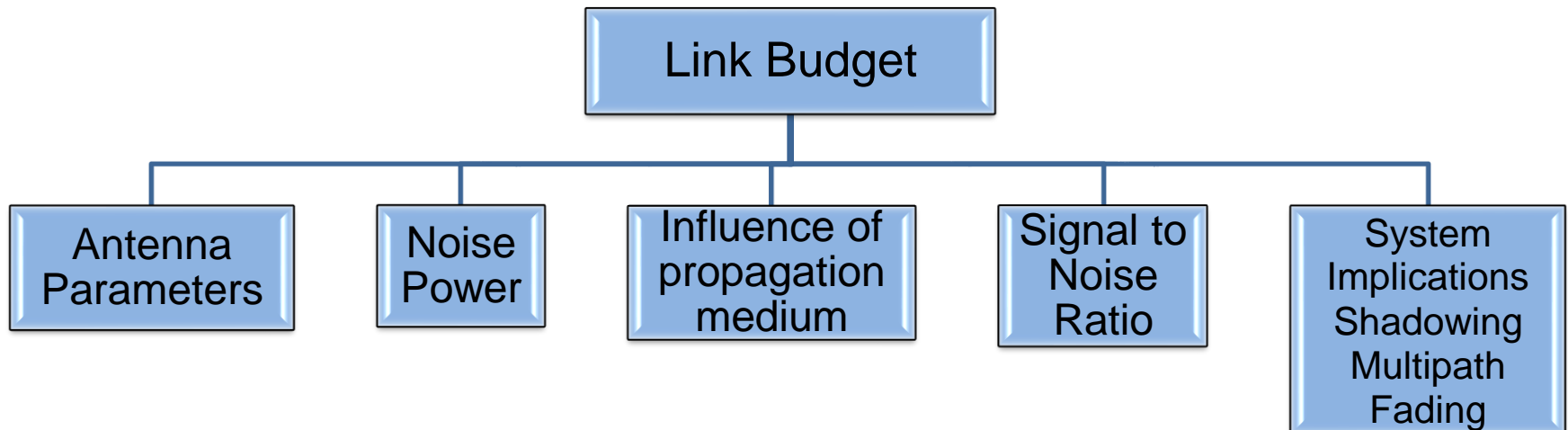

Link Budget: What's that?

Link Budget Analysis: Getting Started

1. A Link Budget analysis determines if there is enough signal power at the receiver to recover the information transmitted to it with **acceptable fidelity** so the received signal can be used.
 - A. The sum of gains and losses in various parts of the system has to result in satisfactory performance (typically, output S/N or BER).
2. The design of any communication link is based on:
 - A. Meeting of minimum C/N ratio for a specific percentage of time.
 - B. Carrying the maximum revenue earning traffic at minimum cost.
3. Link-power budget calculations take into account **all the gains and losses** from the transmitter, through the propagation medium to the receiver in a communication system. Also taken into the account are the attenuation of the transmitted signal due to propagation, and the loss or gain due to the antenna. Link calculations often determine the **maximum distance** at which a transmitter and receiver can successfully operate.

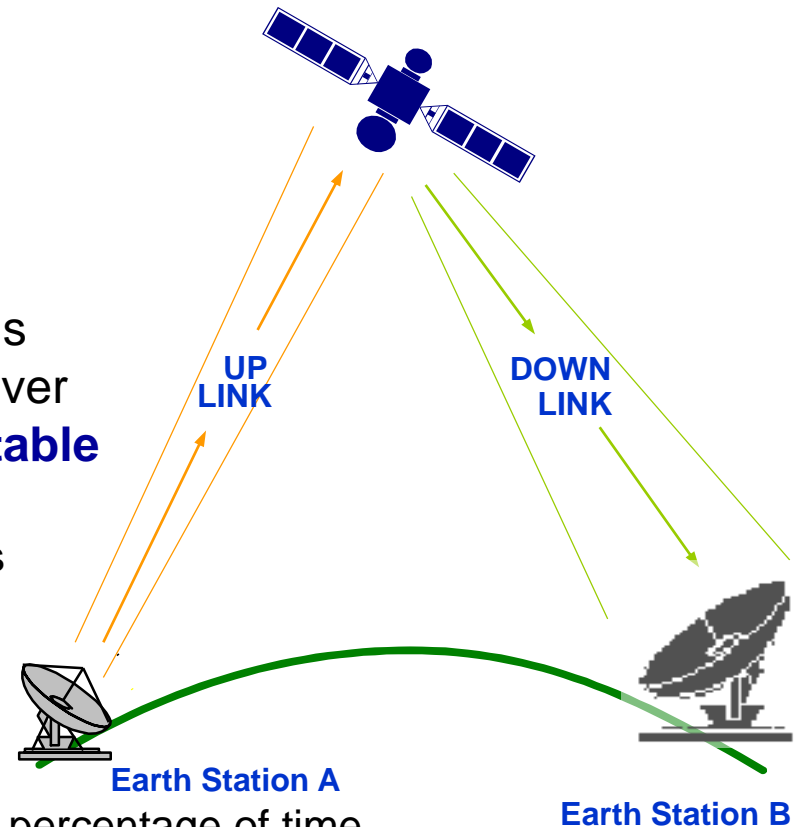

Comm Systems needing a Link Budget Analysis

Link Budget Analysis: Getting Started

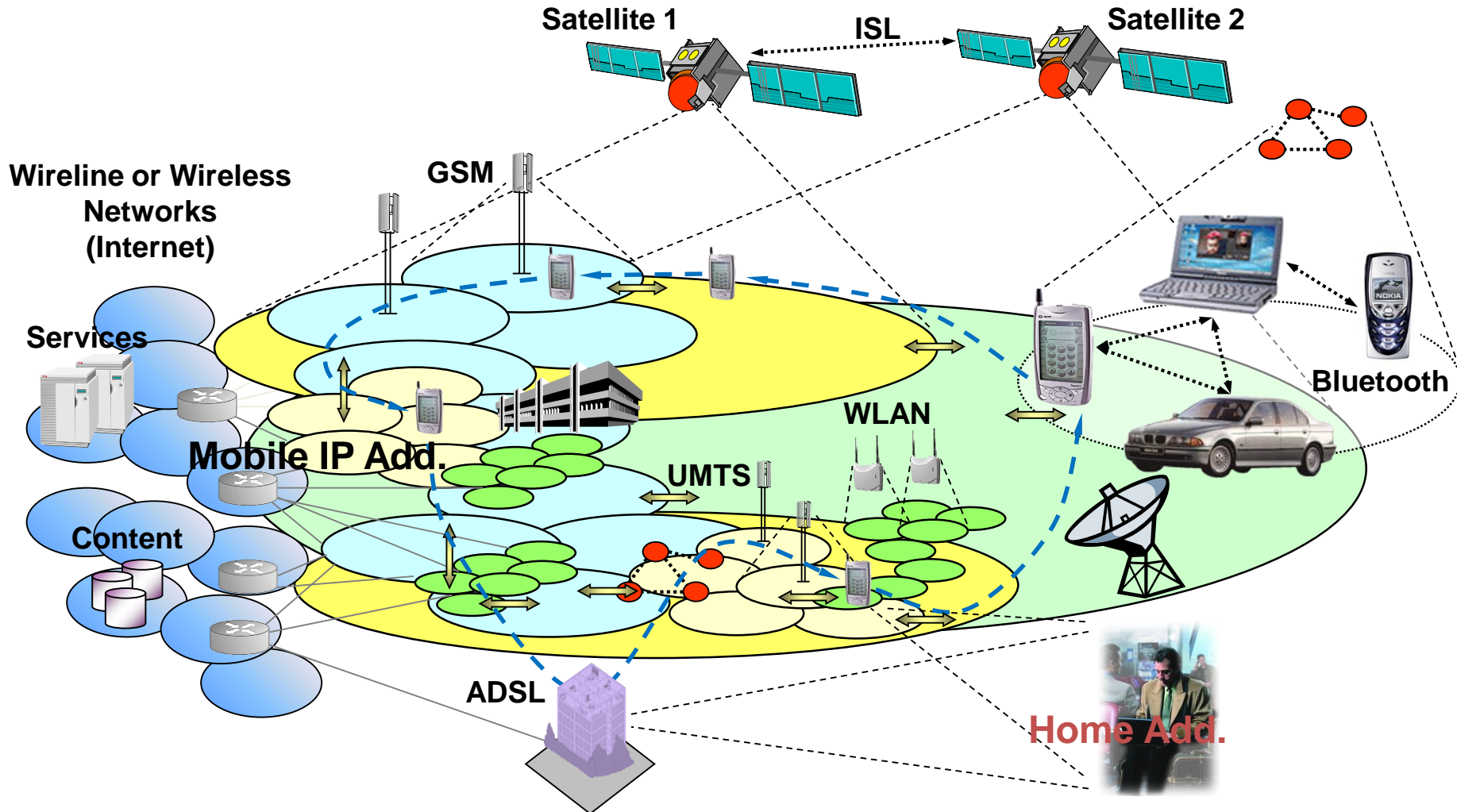

Atlanta RF

Services, Software & Designs

Types of Communication Links

Link Budget Analysis: Getting Started

1. **Point-to-Point** Link: Radio tower relay stations.
2. **Satellite** Link: Communications payload and TT&C signals
 - A. Earth Station to Satellite.
 - B. Satellite-to-Satellite.
 - C. Satellite-to-Earth Station.
3. **Terrestrial** Link:
 - A. Cable/wire to cable/wire
 - B. Fiber optic-to-fiber optic.
4. **Maritime** Link: Ship-to-Ship

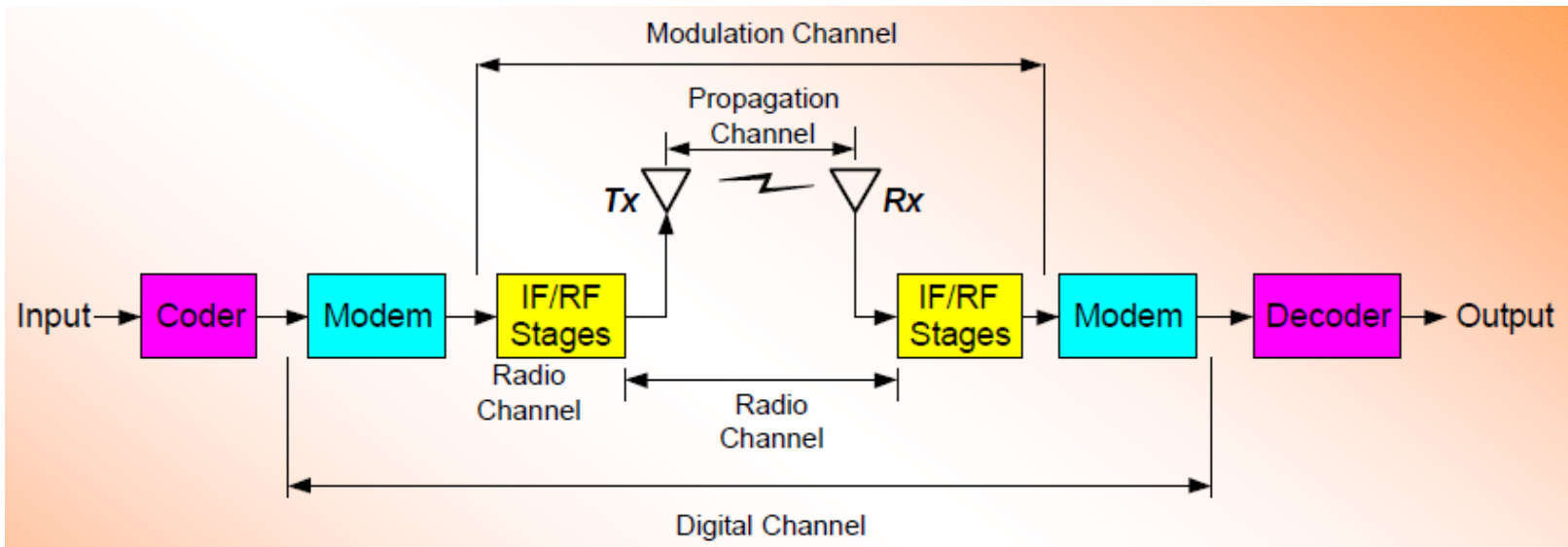

Benefits of a Link Budget Analysis

Link Budget Analysis: Getting Started

1. The overall performance of a communication system is expressed in terms of the ratio of carrier's signal power to noise power: C/N and, ultimately, the **information quality** in the form of:
 - A. Message quality,
 - B. BER: Bit error rate,
 - C. Video impairment, or
 - D. Audio fidelity.
2. Done properly, link analysis can predict if the **operation thresholds** of the communication link are met with satisfactory quality, based on the specifications of the ground components and space components.
3. **Operation thresholds** in the communication link depend on:
 - A. Modulation scheme being used.
 - B. Desired communication quality.
 - C. Coding gain.
 - D. Additional overheads.
 - E. Channel Bandwidth.
 - F. Thermal Noise power.
4. Any uncertainty can be covered by providing an appropriate amount of **link margin**, which is over and above the C/N needed to account for propagation effects and nonlinearity in the system.

Link Budget Objectives

Link Budget Analysis: Getting Started

1. The Link Budget allows us to characterize the quality of the wireless communications link in a **quantitative fashion**.
2. Link Budget is used in the design process to define & “size” parameters and components in the wireless communication system:
 - A. How much RF signal power do I need to transmit/broadcast?
 - B. How big should my antenna be? Or, which antenna should I use?
 - C. How fast can I send data?
 - D. If I use an error detection and correction encoding technique, can I get away with a “noisier” link and therefore save system (& cost) resources elsewhere?
3. **Goals** in communication systems design:
 - A. To maximize transmission bit rate, R_{bit}
 - B. To minimize bit error rate, BER .
 - C. To minimize required power, E_b/N_o .
 - D. To minimize required system bandwidth, B_w .
 - E. To maximize system utilization.
 - F. To minimize systems complexity.

How Many Link Budget Analysis?

Link Budget Analysis: Getting Started

1. Two link budget analysis need to be planned:
 - A. Uplink Analysis: From ground to satellite.
 - B. Downlink Analysis: From satellite to ground.
2. Two-way communication requires **4 link analysis**:
 - A. Example: Maritime communications.
3. One way communication require **2 link analysis**:
 - A. Example: Direct-To-Home TV broadcast.
4. Two communication links often operate at different frequencies within the same frequency band.
5. Two links may not be in the same frequency band.
 - A. Fixed / broadcast satellite services usually use same frequency band, like C-band or Ku-band.
 - B. Mobile satellite services may use different frequency bands, like: L-band uplink & S-band downlink.
6. In some communication systems, satellite links may be combined with terrestrial returns.

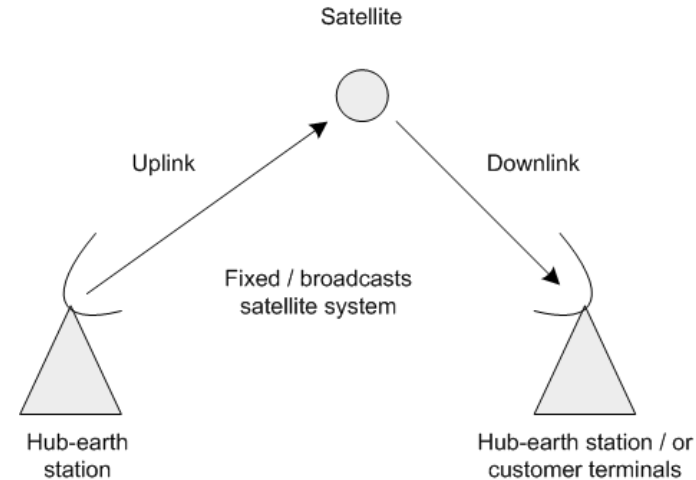

One way communication

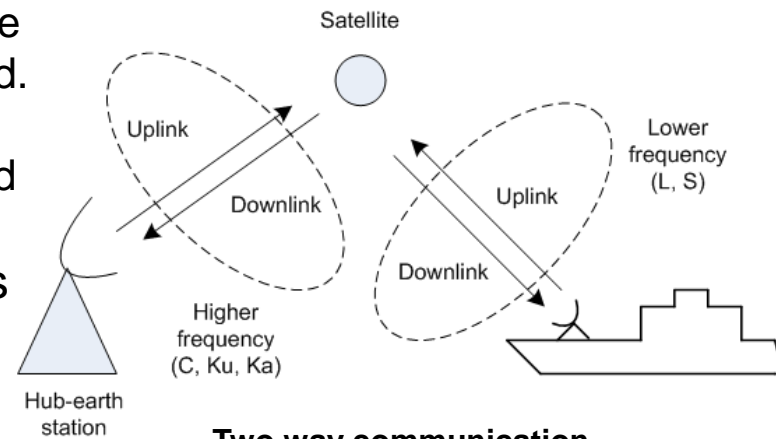

Two way communication

Atlanta RF

Services, Software & Designs

Power Transfer into Free Space

Friis' Transmission Equation

1. In any communication link, there is a transmitting antenna with directional gain: G_{TX} radiating to a receive antenna with directional gain: G_{RX} , separated by a distance: R .
2. The **power flux density**, PFD, at any given distance: R meters, from an ideal lossless isotropic antenna radiating a transmit power P_t is:

$$PFD_{isotropic} = \frac{P_t}{4\pi R^2}, \text{ Watts} / m^2, \text{ where the area of a sphere is: } A_{sphere} = 4\pi R^2, m^2$$

3. The power flux density focused in the direction of maximum radiation by a transmit antenna having a directional gain: G_{TX} is:

$$PFD_t = PFD_{isotropic} \cdot G_{TX} = \frac{P_t G_{TX}}{4\pi R^2}, \text{ watts} / m^2 \quad \text{where: } EIRP = P_t G_t$$

4. The signal power received (P_{rec}) by an antenna having an effective aperture area: $A_{e,r}$ is:

$$P_{rec} = PFD_t \cdot A_{e,r} = \left(\frac{P_t G_{TX}}{4\pi R^2} \right) \cdot A_{e,r} = P_t G_{TX} G_{RX} \left(\frac{\lambda}{4\pi R} \right)^2, \text{ watts} \quad \text{where: } A_{e,r} = \frac{\lambda^2}{4\pi} \cdot G_{RX}$$

5. Rearranging, one obtains Friis' Transmission Equation:

$$P_{rec} = \frac{P_t G_{TX} G_{RX}}{(4\pi R / \lambda)^2}, \text{ watts; where } \text{Free Space Path Loss: } FSPL = (4\pi R / \lambda)^2$$

"Note on a Simple Transmission Formula", Harald Friss,
Proceeding of IRE, Volume 34, p 254-256, May 1946.

Atlanta RF

Services, Software & Designs

Friis' Transmission Equation with Loss

Link Budget Analysis: Getting Started

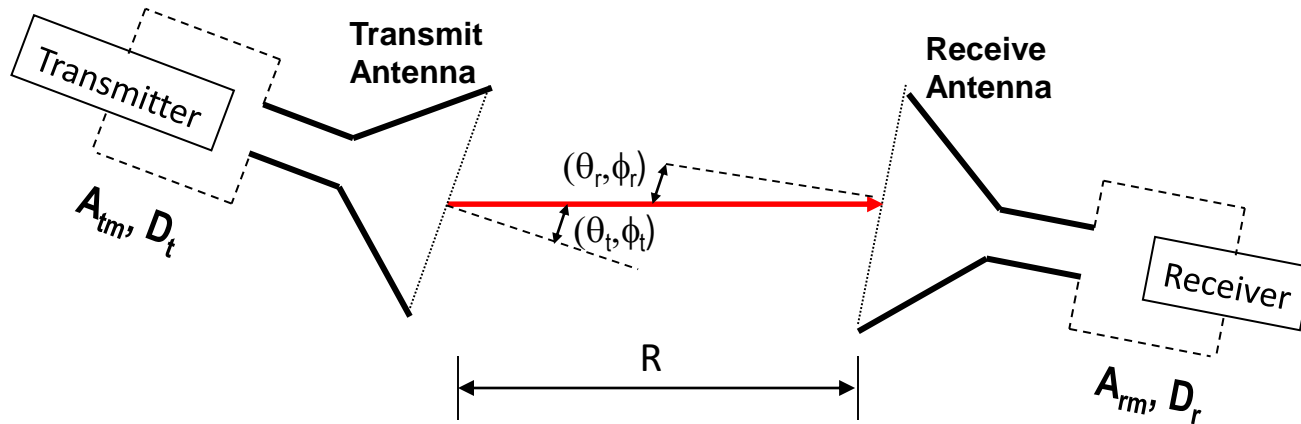

Conductor and Dielectric losses in **Receive antenna**

Reflection loss in **Receive antenna** (impedance mismatch)

Free Space Path Loss

Directivity of **Receive antenna**

$$\frac{P_r}{P_t} = \eta_{cdt} \eta_{cdr} (1 - |\Gamma_r|^2) (1 - |\Gamma_t|^2) \left(\frac{\lambda}{4\pi R} \right)^2 D_{gt}(\theta_t, \phi_t) D_{gr}(\theta_r, \phi_r) |\hat{\rho}_w \cdot \hat{\rho}_a^*|^2$$

Conductor and Dielectric losses in **Transmit antenna**

Reflection loss in **Transmit antenna** (impedance mismatch)

Directivity of **Transmit antenna**

Polarization Mismatch

Atlanta RF

Services, Software & Designs

Link Budget for Receive Power: P_r

Additional Losses to Friss' Transmission Equation

Additional losses are experienced in any wireless communication link, and those losses can be included in Friss' transmission equation as:

$$P_r = \frac{P_t G_{Tx} G_{Rx}}{L_p L_a L_{ta} L_{ra} L_{pol} L_{other} L_r}, \text{ watts}$$

where:

A. $EIRP = P_t + G_{Tx}$, dBW (Effective Isotropic Radiated Power).

B. P_t : RF power delivered to the Transmitting antenna, dBW.

1) P_t = Transmit amplifier's RF output power (P_{out})
minus feeder losses (L_t).

C. G_{Tx} : Directional Gain of the Transmitting antenna, dBi.

D. G_{Rx} : Directional Gain of the Receiving antenna, dBi.

E. Losses in the communication link:

- 1) $L_p = \text{Free-Space Path Loss}$ (FSPL) caused by spherical spreading of the Tx RF signal.
 - a) $L_p = 10 \log_{10} [(4\pi R)^2 / \lambda^2]$; R = Distance, meters; λ = Wavelength of RF signal, meters.
- 2) L_a = Losses due to attenuation in **Earth's atmosphere**.
- 3) L_{ta} = Losses associated with **transmitting antenna**: Ohmic & reflection losses.
- 4) L_{ra} = Losses associated with **receiving antenna**: Ohmic & reflection losses.
- 5) L_{pol} = Losses due to **polarization mismatch**.
- 6) L_{other} = Any other known loss. Include as much detail as available.
- 7) L_r = Additional losses at **receiver** (after receiving antenna).

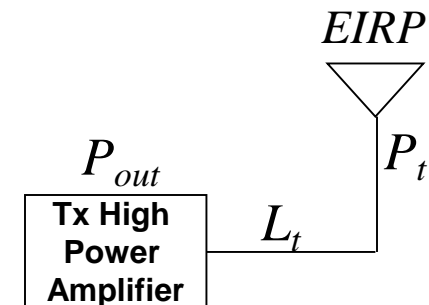

Link Power Budget Equation

Link Budget Analysis: Getting Started

1. Friss' Transmission equation, including all additional losses, forms the **Link Power Budget equation** for the communication system, where each term can be expressed in decibel (dB) form: $10\log_{10}(x)$ as:

$$P_r = EIRP + G_{Rx} - Losses, dBW$$

2. The receive power: P_r is commonly referred to as **Carrier Power: C**, which is measured at the input to the Receiver's Low Noise Amplifier.
3. The major source of loss in any ground-satellite link is the free-space spreading loss (FSPL), represented by L_p in the Link Power equation.
4. **Linear form** for FSPL: **Decibel form** for FSPL:

$$FSPL = (4\pi R / \lambda)^2$$

$$FSPL = 10\log_{10}(4\pi R / \lambda)^2, dB$$

$$FSPL = 96.5 + 20\log(d[\text{miles}]) + 20\log(f[\text{GHz}])$$

$$FSPL = 92.44 + 20\log(d[\text{km}]) + 20\log(f[\text{GHz}])$$

$$FSPL = 147.56 + 20\log(d[\text{m}]) + 20\log(f[\text{Hz}])$$

where:

R = Distance between Tx and Rx.

λ = Wavelength of the RF signal.

Atlanta RF

Services, Software & Designs

Propagation Path Loss Models

Link Budget Analysis: Getting Started

1. Propagation path loss is a reduction in the signal's power, which is a direct result of the distance between the transmitter and the receiver in the communication path. . . . **Spreading loss.**
2. There are many models used in the industry today to estimate the propagation path loss, and the most common are:
 - A. Free Space Path Loss (**FSPL**).
 - B. Hata Path Loss.
 - C. Lee Path Loss.
3. Each propagation path loss model has its own requirements that need to be met in order to be utilized correctly.
4. The Free Space Path Loss (FSPL) is used as the foundation for all propagation path loss models. Used extensively for predicting Point-to-Point, fixed, propagation path loss. Typically underestimates the path loss actually experienced for mobile communications.

Free-Space Path Loss vs Distance: R

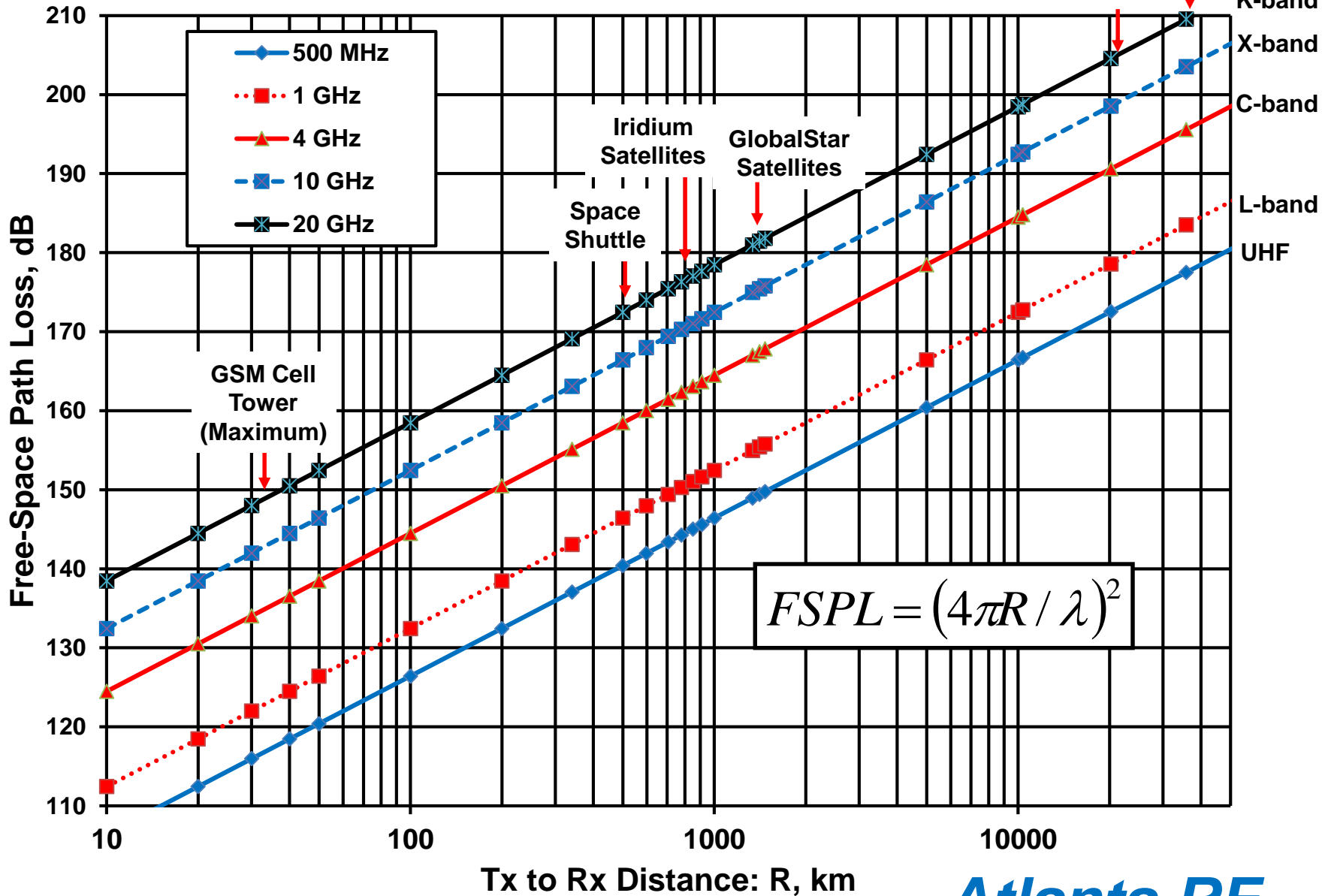

Communication System Noise

Link Budget Analysis: Getting Started



1. Noise in a communication system is caused by thermal noise sources, or can be represented as a thermal noise source:
 - A. Noise sources **external** to the Receive system, such as:
 - 1) Transmitted noise on the communication link.
 - 2) Environmental noise captured by the Receive antenna:
 - a) Antennas pointed at outer space, which appears cold and produces little thermal noise power (about 5°K).
 - b) Onboard satellite antennas pointed towards the Earth capture thermal noise power (about 290 °K):
 - B. Noise sources **internal** to the Receive system, such as:
 - 1) Feed-line losses located before the LNA.
 - 2) Noise from the Receiver's Low-Noise Amplifier (LNA).
2. Different noise sources have different origins but a similar power spectral density, so they can all be **treated as thermal noise**.

N: Noise Power & N₀: Noise Spectral Density

Link Budget Analysis: Getting Started

1. The power available from thermal noise is:

$$N = kT_s B_w, \text{ watts}$$

where:

k = Boltzmann's constant.

= 1.38×10^{-23} Joules/°Kelvin (= -228.6 dBW/°K/Hz)

T_s = Effective system noise temperature, °Kelvin.

B_w = Effective Rx system bandwidth, Hertz.

2. Recall: °Kelvin = °Celsius + 273°.

3. The noise spectral density (density of noise power in a 1 hertz bandwidth) is:

$$N_0 = \frac{N}{B_w} = \frac{kT_s B_w}{B_w} = kT_s, \text{ watts/Hz}$$

4. N_0 : Noise spectral density is constant up to ~300GHz.

Band width: B_w	Thermal Noise Power: N, dBm	Noise = $10 \cdot \log_{10}(B) - 174$, dBm
		Comments
1 Hz	-174	
10 Hz	-164	
100 Hz	-154	
1 kHz	-144	
3 kHz	-139	Telephone voice channel
10 kHz	-134	FM channel of 2-way radio
100 kHz	-124	
180 kHz	-121.42	One LTE resource block
200 kHz	-120.96	One GSM channel (ARFCN)
1 MHz	-114	
2 MHz	-111	Commercial GPS channel
6 MHz	-106	Analog TV channel
20 MHz	-101	WLAN 802.11 channel
36 MHz	-98	Satellite channel
72 MHz	-95	

Thermal Noise Power: N, at $T_s = 290^\circ\text{K}$

Noise & Noise Figure: NF

Link Budget Analysis: Getting Started

1. System Noise Temperature: T_s is the temperature above 0° Kelvin, where there is no random motion of electrons in matter:

$$T_s = T_a + T_e, \text{ }^\circ\text{Kelvin}$$

where: T_e is the Rx noise temperature.

T_a = Sky noise + Antenna losses.

2. The Receiver's noise temperature is related to its Noise Figure as:

$$T_e = T_o(F_{\text{sys}} - 1), \text{ where } T_o = 290^\circ\text{K.}$$

3. The noise factor: $F_{\text{sys}} = 10^{\text{NF}/10}$,
where NF = Noise Figure.

4. Then, the noise factor: $F_{\text{sys}} = 1 + T_e/T_o$.

T_e °Kelvin	Noise Factor: F_{sys}	Noise Figure dB		Noise Figure dB	Noise Factor: F_{sys}	T_e °Kelvin
10	1.034	0.147		0.10	1.023	6.75
20	1.069	0.290		0.20	1.047	13.67
30	1.103	0.428		0.30	1.072	20.74
40	1.138	0.561		0.40	1.096	27.98
50	1.172	0.691		0.50	1.122	35.39
60	1.207	0.817		0.60	1.148	42.96
70	1.241	0.939		0.70	1.175	50.72
80	1.276	1.058		0.80	1.202	58.66
90	1.310	1.174		0.90	1.230	66.78
100	1.345	1.287		1.00	1.259	75.09
150	1.517	1.811		2.00	1.585	169.62
200	1.690	2.278		3.00	1.995	288.63
250	1.862	2.700		4.00	2.512	438.45
298	2.028	3.070		5.00	3.162	627.06
400	2.379	3.765		6.00	3.981	864.51
500	2.724	4.352		7.00	5.012	1163.44

Antenna Noise

Link Budget Analysis: Getting Started

1. Antenna noise temperature includes noise components **captured** from the environment surrounding the antenna and the noise generated by losses within the antenna, both ohmic loss and reflected mismatch loss.
2. The antenna noise temperature is the result of integrating the antenna's three-dimensional radiation pattern with the incremental noise temperatures over spherical space. Typically, the environmental noise temperature varies with the antenna's **elevation angle**: φ
 - The noise temperature below the horizon may be considered as 290 °K.
 - The noise temperature at the local zenith may be less than 5 °K.
 - Low on the horizon, the noise temperature varies from 290 °K at the horizon to 100 °K at very low elevation angles near the horizon to 5 °K near the zenith.
3. For low link margin communications systems, it is generally important to **minimize** the antenna temperature. Therefore, a half-power beam width somewhat less than 180° tends to lower the antenna noise temperature.

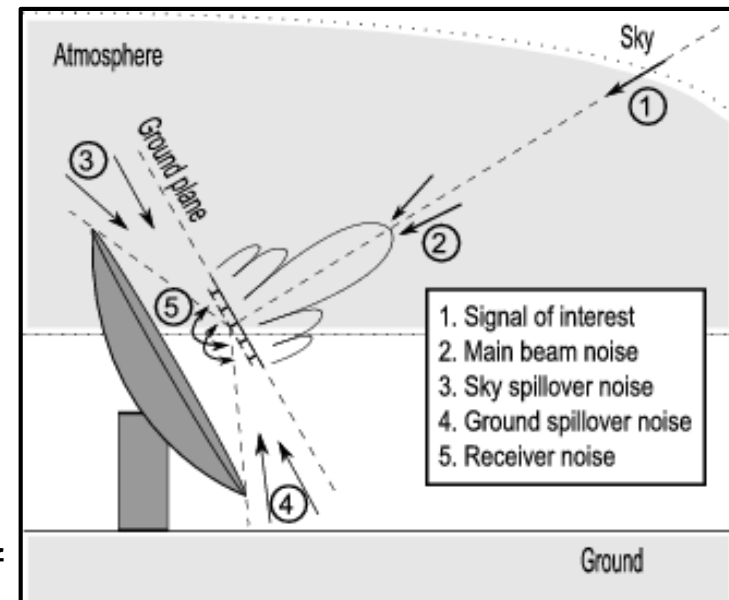

Antenna Noise Temperature: T_a

Link Budget Analysis: Getting Started

Useful approximation for Earth Station antenna temperature on clear sky:

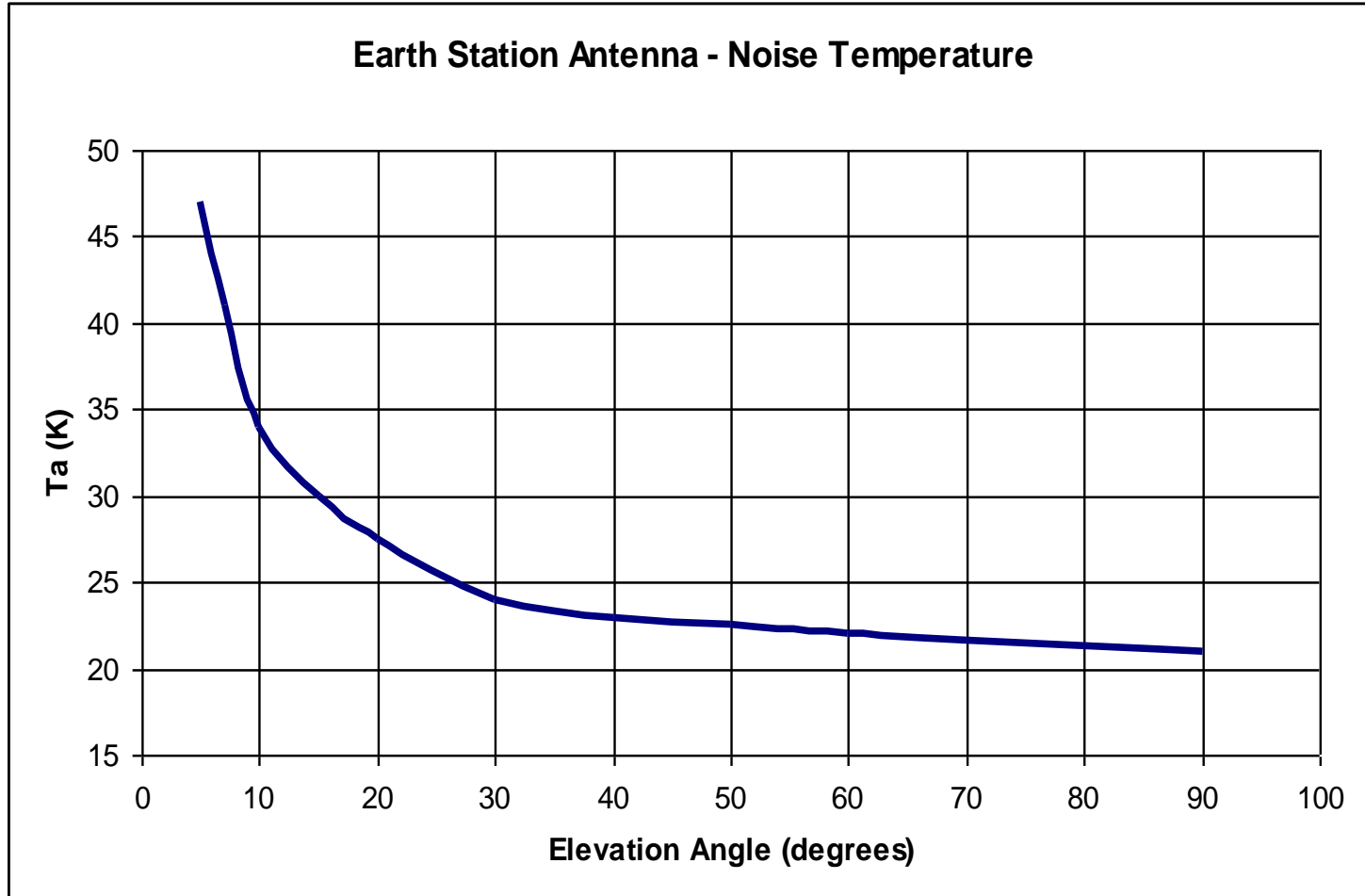

Atmospheric & Sky Noise Temperatures

Standard Atmosphere

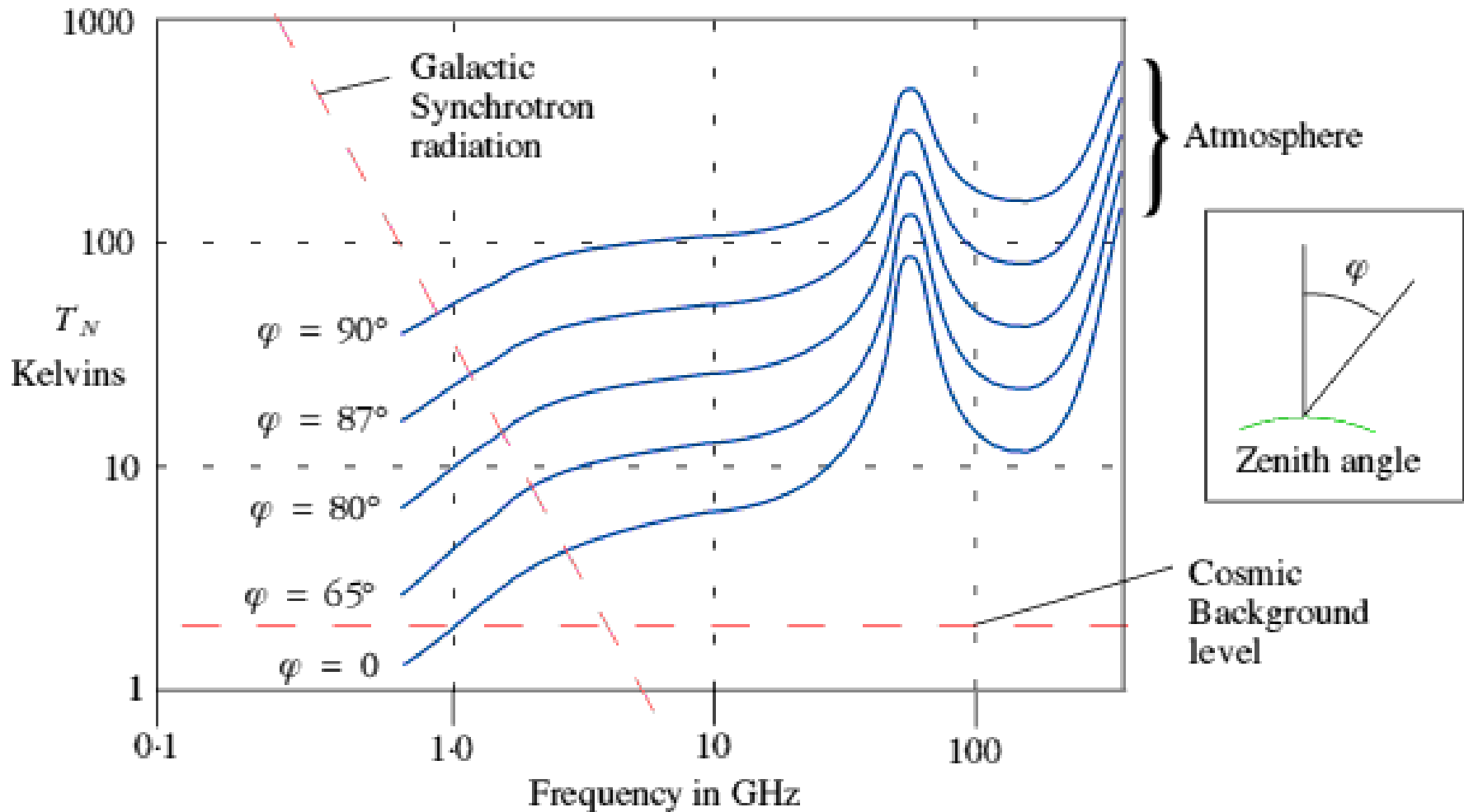

S/N: Signal-to-Noise ratio

Link Budget Analysis: Getting Started

1. External & internal system noise will add to the receive signal/carrier power to produce a Signal-to-Noise ratio: S/N, in **linear form**:

$$\frac{\text{Signal}}{\text{Noise}} = \frac{S}{N} = \frac{P_r}{kT_s B_w} = \frac{P_T G_{Tx} G_{Rx}}{\text{Losses}} \cdot \left(\frac{1}{kT_s B_w} \right) = \frac{P_T G_{Tx}}{k B_w} \cdot \left(\frac{1}{\text{Losses}} \right) \cdot \left(\frac{G_{Rx}}{T_s} \right)$$

where: $\text{Signal} = P_r = \frac{P_T \cdot G_{Tx} \cdot G_{Rx}}{\text{Losses}}$, watts and $\text{Noise} = kT_s B_w$, watts.

2. The above Signal-to-Noise ratio is expressed in **decibel form** as:

$$\left(\frac{S}{N} \right) = \left(\frac{C}{N} \right) = \text{EIRP} - \text{Losses} + \left(\frac{G_{Rx}}{T_s} \right) - 10 \log_{10}(k B_w), \text{ dB}$$

where: $\text{EIRP} = 10 \log_{10}(P_t G_{Tx})$ = Effective Isotropic Radiated Power, dBW.

3. Note that the term: G_{Rx}/T_s is the **System's Figure of Merit** and is only related to the receive system.

Closing the Link

Link Budget Analysis: Getting Started

1. Calculate the Link Budget to verify if we are “**closing the link**”.
When the received power is greater than the minimum acceptable carrier power, then the link is ‘closed’:

$$P_r \geq C_{\min} \rightarrow \text{Link closed}$$

$$P_r < C_{\min} \rightarrow \text{Link not closed}$$

2. To ensure acceptable operation in the communication system, assign a “**Link Margin**” in the Link Budget calculations, which tells how tight we are in closing the link:

$$\text{Link Margin} = P_r - C_{\min} \text{ (usually expressed in dB)}$$

3. Equivalently:

$$\text{Link Margin} > 0 \rightarrow \text{Link closed.}$$

$$\text{Link Margin} < 0 \rightarrow \text{Link not closed.}$$

Link performance and availability

Link Budget Analysis: Getting Started

Two thresholds are defined:

1. **Performance** threshold: Link's performance above targeted value.
2. **Availability** threshold: Link is not available due to bad performance.

Key link budget equation:

$$P_r = EIRP + G_{Rx} - FSPL - L_a, \text{ dB}$$

where:

P_r : Received power, dBw.

EiRP: $P_t G_{Tx}$, dB.

FSPL: Free space path loss, dB.

L_a : Atmospheric losses, dB.

Note: L_a is a random variable that changes due to condition of the atmosphere between Tx and Rx.

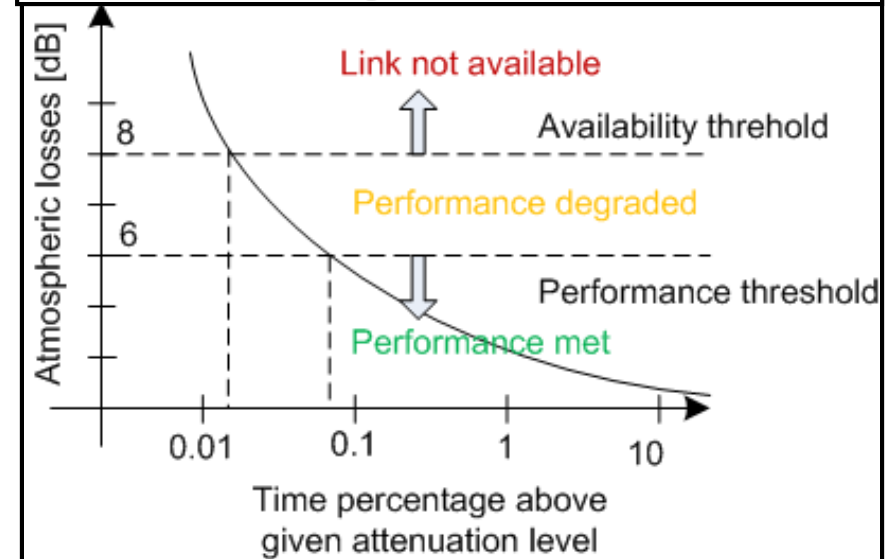
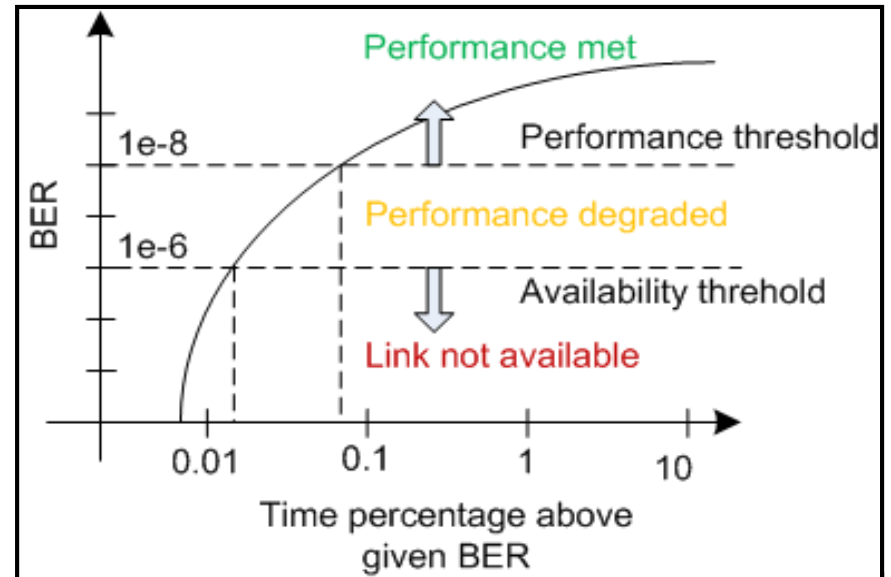

Digital Transmission

Link Budget Analysis: Getting Started

1. Analog communications mostly use mean signal power over mean noise power: S/N as a quality parameter.
2. In **analog** communications, a waveform can be imagined as a signal with infinitely long duration and not divided in time, therefore with an unlimited amount of energy. It has finite mean power and infinite energy. Therefore, power is a useful parameter for analog communications.
3. With **digital** communications, symbols are transmitted in a time: T_s . If only one symbol is observed, mean power in all the time interval approaches zero. Therefore, power is not a satisfactory parameter for digital systems.
4. In digital communications, more often is used E_b/N_0 , or *normalized version of signal and noise*:

$$\frac{S}{N} = \frac{E_b}{N_0} \frac{R_{bit}}{B_w}$$

where: E_b is the energy per bit, watt-second.

N_0 is thermal noise in 1 Hz bandwidth, watts/Hz.

R is the data speed in the system, bits per second (bps).

B_w is the frequency bandwidth, Hz.

Link Performance Criteria

Link Budget Analysis: Getting Started

1. For **analog** communication systems, the link performance criteria that determines signal quality is Signal-to-Noise Ratio: **S/N**.
 1. Signal: S = Power level of signal in occupied bandwidth, dBW or dBm.
 2. Noise : N = Noise power in occupied bandwidth, dBW or dBm.
2. For **digital** communication systems, the link performance criteria that determines signal quality is Bit Error Rate (**BER**)/Probability of Error.
 - A. BER is directly related to E_b/N_o and improves as E_b/N_o gets larger.
 - B. $E_b = P_r/R_{bit}$ = Received power/Bit rate, Watts/bits/sec. R_{bit} = Bit rate, bps
 - C. N_o = Noise power per unit of bandwidth = Noise power density, dBW/Hz.
3. S/N or BER is measured at the demodulator's output, so they are specified at baseband frequencies:
 - A. S/N = 40 dB in television; S/N = 30 dB in analog speech channels.
 - B. S/N = 36 to 40dB for FM television \rightarrow C/N = 8 to 12dB in demodulator's (modem's) input.
 - C. BER < 10^{-6} in data channels \rightarrow C/N = 12 dB (QPSK) at demod's input.
4. S/N and BER depend on C/N and on the modulation technique.

E_b : Energy per bit

Link Budget Analysis: Getting Started

1. Since **Energy = Power x Time**, the receive signal power: S (watts) in a digital communication link is related to the energy in the bit interval: E_b (watt-second,) during the bit time interval: T_{bit} (sec) as:

$$E_b = S * T_{bit} = \frac{S}{R_{bit}}, \text{ watt-sec}$$

where: $R_{bit} = 1/T_{bit}$ = User bit rate; number of bits transmitted each second.

2. Expressing the equation in terms of Energy per bit: E_b

$$E_b = \frac{S}{R_{bit}} = \frac{P_r}{R_{bit}} = \frac{C}{R_{bit}}, \text{ watt - sec}$$

3. Where: $S = P_r = C$ = Received signal/carrier power, watts.

E_b/N_0 : Energy per bit/Noise Spectral Density

Link Budget Analysis: Getting Started

1. E_b/N_0 is the performance criterion for any desired Bit Error Rate.
 - A. To represent the minimum carrier performance before link failure.
 - B. Is used as the basic measure of how strong the received signal is.
 - C. It is the measure at the input to the receiver.
 - D. Directly related to the amount of power transmitted from the uplink station.
2. E_b/N_0 is equal to the Signal-to-Noise ratio divided by the "gross" link spectral efficiency in (bit/s)/Hz, where the bits in this context are transmitted data bits, inclusive of error correction information and other protocol overhead.
3. E_b/N_0 expressed in **linear form**: Expressed in **decibel form**:

$$\frac{E_b}{N_0} = \frac{S}{N} \frac{B_w}{R_{bits}}$$

$$\frac{E_b}{N_0} = \frac{S}{N} + B_w - R_{bits}, dB$$

4. $E_b/N_0 = (S/N) + \text{Noise Bandwidth} - \text{Information Rate}, dB.$

Sources of Link Degradation

Link Budget Analysis: Getting Started

1. Signal **Attenuation/Fading**:

- A. A time-varying response.
- B. Amplitude/envelop/gain/power attenuation.

2. Signal **Distortion**:

- A. Distortion can be introduced within the Transmitter, Receiver or in the channel.
- B. The common types of link distortion are:
 - 1) Frequency-dependent phase shift.
 - 2) Gain variation with frequency caused by channel filtering effects.
 - 3) Gain variation with time as seen in radio/infrared channels.
 - 4) Frequency offsets between Tx & Rx due to Doppler shift or local oscillator errors.
- C. Distortion can be corrected with equalization or gain/frequency control systems.

3. Signal **Interference**:

- A. Interference arises due to signal contamination in the channel by extraneous signals.
Most interference signals are impulsive.

4. **Noise**:

- A. Noise is characterized as random, unpredictable electrical signals from natural sources such as: Atmospheric noise, Thermal noise, Shot noise, etc.
- B. Because of the multiplicity of noise sources, it is difficult to define.
- C. It is commonly assumed that noise in communication links fall into the class of Additive White Gaussian Noise (AWGN).

Summary: Link Budget Equations

Link Budget Analysis: Getting Started

1. Effective Isotropic Radiated Power:

$$EIRP = 10 \log_{10}(P_t * G_{Tx}), \text{ dBW}$$

2. Receive Signal Power:

$$P_r = S = \frac{P_t G_{Tx} G_{Rx}}{L_p L_a L_{ta} L_{ra} L_{pol} L_{other} L_r}, \text{ watts}$$

$$P_r = S = EIRP + G_{Rx} - \text{Losses}, \text{ dBW}$$

3. Free Space Path Loss: FSPL

$$FSPL = 10 \log_{10}(4\pi R / \lambda)^2, \text{ dB}$$

4. System Noise:

$$N = kT_s B_w, \text{ watts}$$

5. Signal-to-Noise Ratio:

$$\left(\frac{S}{N}\right) = \left(\frac{C}{N}\right) = EIRP - \text{Losses} + \left(\frac{G_{Rx}}{T_s}\right) - 10 \log_{10}(kB_w), \text{ dB}$$

6. Energy per bit:

$$E_b = S * T_{bit} = \frac{S}{R_{bit}}, \text{ watt-sec}$$

7. Energy/bit per Noise density:

$$\frac{E_b}{N_0} = \frac{S}{N} + B_w - R_{bits}, \text{ dB}$$

8. Noise spectral density:

$$N_0 = \frac{N}{B_w} = \frac{kT_s B_w}{B_w} = kT_s, \text{ watts/Hz}$$

Atlanta RF

Services, Software & Designs



Atlanta RF

Services, Software & Designs

Atlanta RF LLC was founded to provide engineering solutions, design software solutions, and product development solutions to the high-frequency RF/microwave industry in the areas of: Telecommunications (ground segment), Satellite (space segment) and military/defense (RF front-ends).

Through teamwork, Atlanta RF applies our diverse technical experience to your project's challenges with creative and innovative solutions while holding ourselves accountable for the results. With professionalism and commitment to our clients, Atlanta RF will be there for you, both today and tomorrow.

Contact Atlanta RF by e-mail at:

- Atlanta RF **Services** : Services@AtlantaRF.com
- Atlanta RF **Software** : Sales@AtlantaRF.com
- Atlanta RF **Designs** : Designs@AtlantaRF.com

Or, contact Atlanta RF by phone at: 678-445-5544, to reach our Atlanta-area office in Georgia, USA, and discuss our support to your current or future projects & products.

Atlanta RF

Services, Software & Designs

Presentations by Atlanta RF, LLC

Download various presentations at our website: www.AtlantaRF.com :

1. Satellite: LEO, MEO & GEO.
2. Antennas: An Overview.
3. Link Budget: Getting Started.
4. Link Budget: Digital Modulation Part 1 (Overview & M-ASK).
5. Link Budget: Digital Modulation Part 2 (M-FSK).
6. Link Budget: Digital Modulation Part 3 (M-PSK & QAM).
7. Link Budget: Error Control & Detection.
8. Multiple Access Techniques: FDMA, TDMA and CDMA.
9. Insertion Loss: Double Ridge Waveguide.
10. RF Filters: An Overview.
11. Multi-Section Symmetrical Directional Couplers.
12. Parallel Coupled Bandpass Filters.

Visit our website often as presentations are added for your viewing pleasure.

Atlanta RF

Services, Software & Designs